

EX-801AL & EX-801A EX-801BL & EX-801B

Exquisite Exit Buttons

ZKT_{ECO}



EX-801AL EX-801A



EX-801BL



EX-801B



Features

- Press to open the door
- 100,000 times of MCBF
- Stainless steel metal case
- Flame-retardant and corrosion-resistant

Applications

- Weak electricity system
- Access control system
- Anti-theft system

Specifications

Model	EX-801AL	EX-801A	EX-801BL	EX-801B
MCBF	100,000		100,000	
Working Voltage	DC 12V to 36V		DC 12V to 36V	
Interface	NO, COM		NO, COM	
Product Material	SU201 Stainless Steel Panel Switch	SU304 Stainless Steel Panel Switch	SU201 Stainless Steel Panel Switch	SU304 Stainless Steel Panel Switch
	Laser Engraving	Silkscreen	Laser Engraving	Silkscreen
Working Temperature	-10°C to 55°C		-10°C to 55°C	
Working Humidity	0% to 95%		0% to 95%	
Storage Temperature	-15°C to 60°C		-15°C to 60°C	
Storage Humidity	0% to 95%		0% to 95%	
Product Dimensions (L*W*H)	91*28*16 (mm)	92*29*25 (mm)	86*86*25 (mm)	91*91*28 (mm)
Package Dimensions (L*W*H)	92*35*35 (mm)	120*94*43 (mm)	104*92*48 (mm)	120*94*43 (mm)
Net Weight	2.2g	2.5g	5.0g	5.6g
Gross Weight	3.4g	5.6g	7.8g	8.7g

Dimensions (mm)

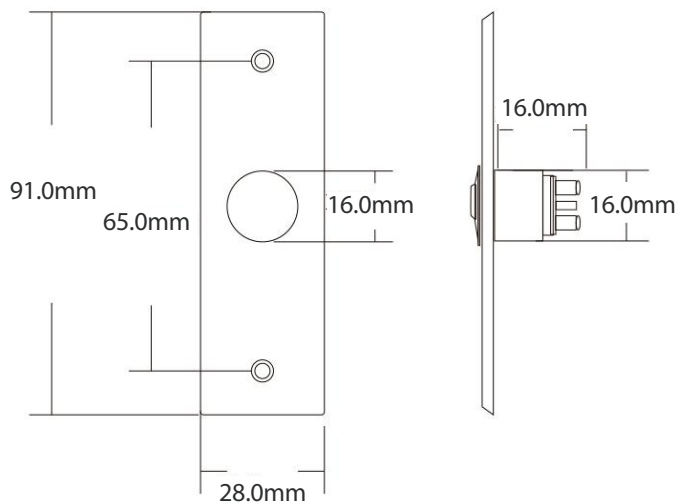

EX-801AL

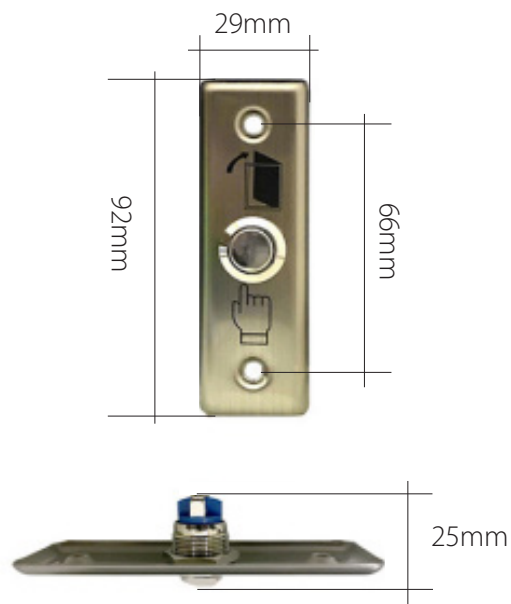

EX-801A

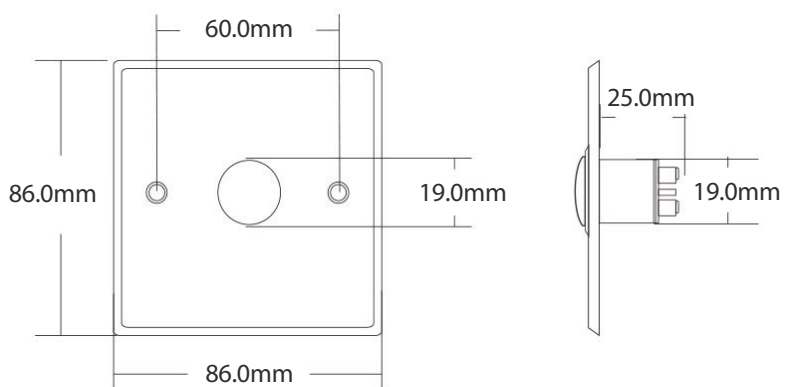

EX-801BL

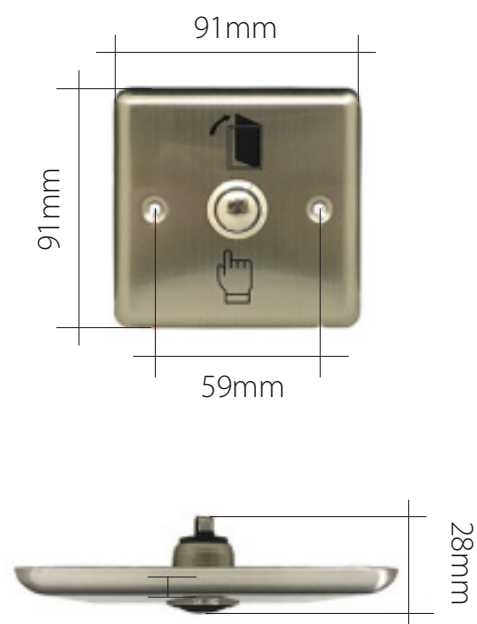

EX-801B

